

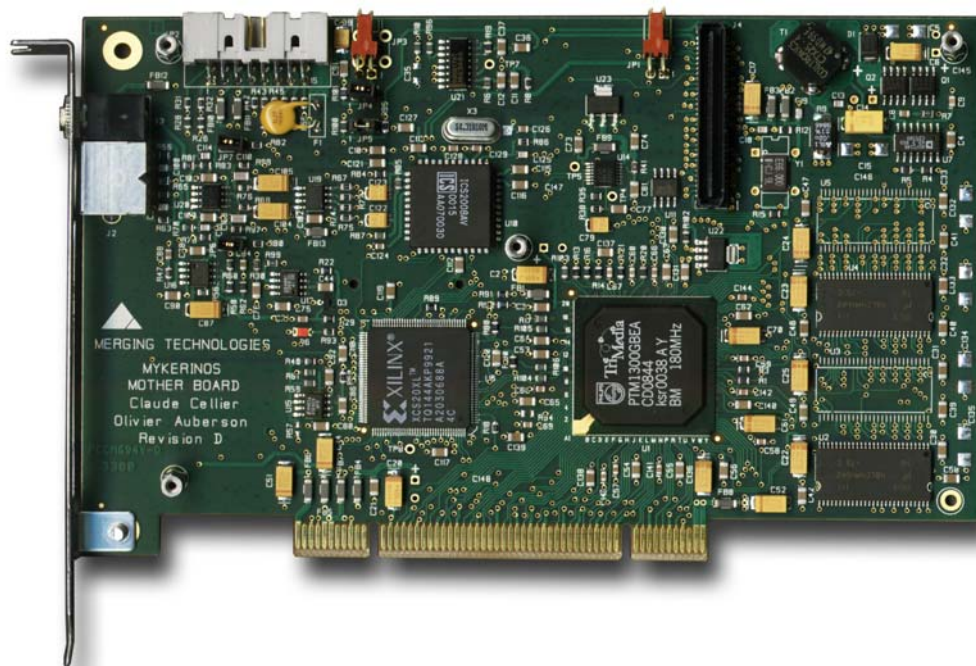

Mykerinos

The Audio Processing Board



User Manual

1 IMPORTANT NOTICE:

Please read the following information very carefully before attempting any installation. Failure to comply with the precise instructions may result in damage to your Merging hardware. Please read this entire section of the manual carefully before installation.

1.1 STATIC DANGER NOTICE:

Please note that the Mykerinos board contains delicate electronic components that can be damaged or even destroyed when exposed to static electricity. Take all necessary precautions not to discharge static electricity when touching any of the Mykerinos components.

1.2 INFORMATION FOR THE USER:

Mykerinos and its daughter card comply with the following specifications:

EMC Emissions

EN 55022 : 1994 /A1 : 1995 /A2 : 1997 Class A ITE emissions requirements (EU)
FCC 47 CFR Part 15 Class A emissions requirements (USA)

EMC Immunity

EN 50082-1: 1992 EMC residential, commercial and light industrial generic immunity standard.

FCC Notice

This product has been tested and found to comply with the limits for a Class A digital device, pursuant to Part 15 of the FCC rules. Operation is subject to the following two conditions: (1) This device may not cause harmful interference, and (2) This device must accept any interference received, including interference that may cause undesired operation.

These limits are designed for providing reasonable protection against harmful interference in a residential installation. This equipment generates, uses and can radiate radio frequency energy and, if not installed and used in accordance with the instructions contained in this manual, may cause harmful interference to radio and television communications. However, there is no guarantee that interference will not occur in a particular installation.

NOTE: Connecting this device to peripheral devices that do not comply with CLASS A requirements or using an unshielded peripheral data cable could also result in harmful interference to radio or television reception. The user is cautioned that any changes or modifications not expressly approved by the party responsible for compliance could void the user's authority to operate this equipment. To ensure that the use of this product does not contribute to interference, it is necessary to use shielded I/O cables.

CE Notice

Such a  marking is indicative that this system's devices meet the following applicable technical standards:

- EN 55022 – “Information Technology Equipment - Radio disturbance characteristics Limits and methods of measurement”
- EN 50082-1: 1992 – “Electromagnetic compatibility – Generic immunity standard Part 1: Residential, commercial, and light industry”

This product is classified for use in a typical Class A commercial environment, and is not designed or intended for use in other EMC environments. The user of this product is obliged for proper use and installation of the product and for taking all steps necessary to remove sources of interference to telecommunications or other devices.

2 Mykerinos Warranty Information

This product is warranted to be free of defects in materials and workmanship for a period of one year from the date of purchase. Merging Technologies, Inc. extends this Limited Warranty to the original purchaser.

In the event of a defect or failure to conform to this Limited warranty, Merging Technologies, Inc. will repair or replace the product without charge within sixty (60) days. In order to make a claim under this limited warranty, the purchaser must notify Merging Technologies, Inc. or their representative in writing, of the product failure. In this limited warranty the customer must upon Merging Technologies, Inc. request, return the product to the place of purchase, or other local designation, for the necessary repairs to be performed. If the consumer is not satisfied with the repair, Merging Technologies, Inc. will have the option to either attempt a further repair, or refund the purchase price.

This warranty does not cover: (1) Products which have been subject to misuse, abuse, accident, physical damage, neglect, exposure to fire, water or excessive changes in the climate or temperature, or operation outside maximum rating. (2) Products on which warranty stickers or product serial numbers have been removed, altered or rendered illegible. (3) The cost of installations, removal or reinstallation. (4) Damages caused to any other products.

3 Table of Contents

1	IMPORTANT NOTICE:	2
1.1	STATIC DANGER NOTICE:.....	2
1.2	INFORMATION FOR THE USER:.....	2
2	MYKERINOS WARRANTY INFORMATION	3
3	TABLE OF CONTENTS	4
4	INTRODUCTION	6
5	MYKERINOS FEATURES OVERVIEW	6
6	MYKERINOS BLOCK DIAGRAM	7
6.1	MYKERINOS BLOCK DIAGRAM.....	7
6.2	MYKERINOS ON-BOARD CONNECTORS AND JUMPERS.....	7
6.3	MYKERINOS BRACKET VIEW.....	8
7	SYNC FEATURES	9
7.1	SIGNAL DESCRIPTION.....	9
7.1.1	CVS1 IN.....	9
7.1.2	CVS2IN / WCKIn&Out.....	9
7.1.3	CVS OUT.....	10
7.1.4	LTC IN.....	10
7.1.5	LTC OUT.....	10
7.2	BREAKOUT CABLE PIN-OUT DESCRIPTION (J2).....	10
7.3	VIDEO/TC HEADER PIN-OUT DESCRIPTIONS (JP2).....	11
8	MONITORING HEADPHONE FEATURES (J3)	12
8.1	MONITORING OUTPUT CHARACTERISTICS.....	12
9	MYKERINOS MODULAR I/O DAUGHTER CARDS	13
9.1	ADAT I/O DAUGHTER CARD.....	13
9.1.1	Optical I/O configuration.....	13
9.2	MADI I/O DAUGHTER CARD.....	14
9.2.1	Coaxial version connector view.....	14
9.2.2	Optical version connector view.....	14
9.3	AES-EBU, SDIF, TDIF I/O DAUGHTER CARDS.....	15
9.3.1	AES-EBU without SRC.....	15
9.3.2	AES-EBU with SRC on 8 channels.....	15
9.3.3	SDIF.....	15
9.3.4	TDIF.....	15
9.4	DUAL DAUGHTER CARD.....	17
9.4.1	Card Features.....	17
9.4.2	Front connector.....	18
9.4.3	Rear 0 connector.....	18
9.5	BREAKOUT CABLE CONNECTORS FOR AES, SDIF, TDIF AND DUAL DAUGHTER CARDS.....	19
9.5.1	Analog I/O breakout cable – <i>Only for the DUAL daughter card</i>	19
9.5.2	AES/EBU I/O breakout cable.....	19

10	TYPICAL AUDIO CONNECTIONS BETWEEN DUA II & MYKERINOS	20
10.1	AUDIO FOR VIDEO WITH SONY DIGITAL BETA CAM USERS.....	20
10.2	AUDIO FOR VIDEO WITH SONY ANALOG BETA CAM USERS	21
10.3	MERGING TECHNOLOGIES PYRAMIX 3.X DAW WITH SURROUND MONITORING	22
11	TYPICAL AUDIO CONNECTIONS BETWEEN SPHYNX & MYKERINOS.....	23
11.1	AUDIO FOR VIDEO WITH SONY® DIGITAL BETA CAM USERS	23
11.2	AUDIO FOR VIDEO WITH SONY® ANALOG BETA CAM USERS	24
11.3	MERGING TECHNOLOGIES PYRAMIX 3.X DAW SETUP	25
12	MYKERINOS POWER CONSUMPTION.....	26
12.1	MYKERINOS	26
12.2	MYKERINOS & ADAT DAUGHTER CARD	26
12.3	MYKERINOS & MADI DAUGHTER CARD	26
12.4	MYKERINOS & AES-EBU WITHOUT SRC	26
12.5	MYKERINOS & AES-EBU WITH SRC.....	26
12.6	MYKERINOS & SDIF OR TDIF DAUGHTER CARDS	27
12.7	MYKERINOS & ANALOG – AES/EBU (DUAL) DAUGHTER CARD.....	27
13	CONTACTING MERGING.....	28

4 Introduction

This document presents and describes the third generation Merging hardware/software solution, a PCI based, high performance, cost effective audio processing card named **MYKERINOS**.

5 Mykerinos Features Overview

Mykerinos is Merging's answer to create a leading edge high performance audio processing card solution. It builds upon over 6 years of experience designing and manufacturing PC based Audio Cards and incorporates hundreds of users feedbacks into a compact third generation flexible solution.

Here is a quick summary of features:

- PCI V2.1 compliant. Supports both 5 Volts and 3.3 Volts PCI environments.
- Driver support for Windows 98 / NT / 2000.
- Very cost effective
- Based on 2nd generation Philips Trimedia 32 bit floating point processing VLIW technology
- High Performance (> 288 MFlops sustained, 576 MB/s SDRAM interface, etc.)
- Support for all sampling rates from 32 kHz up to 384 kHz (needs full version of Pyramix above 48 kHz)
- Open Plug-In (all C-code) architecture supporting Surround-sound and DVD formats
- Highly flexible modular I/O architecture can be tailored to user's needs by the use of dedicated daughter boards. This I/O modularity offers a unique opportunity to meet a wide range of market requirements
- Current Audio I/O daughter card options include ADAT - S/PDIF, MADI, AES/EBU, TDIF, SDIF and DUAL.
- On board Sync Connector, which includes Video Sync I/O ready for HDTV, VITC reader and generator, LTC reader and generator and built-in time code insertion into Video window.
- 2 channel 24 bit 96 kHz on-board monitoring output.
- Very high performance card capable of high track playback (up to 64 tracks) and vast I/O capabilities (up to 64 channels)
- Multiple cards interconnected through HDTDM (High Definition Time Domain Multiplex) bus with support of up to 256 audio channels.

6 Mykerinos Block Diagram

6.1 Mykerinos Block Diagram

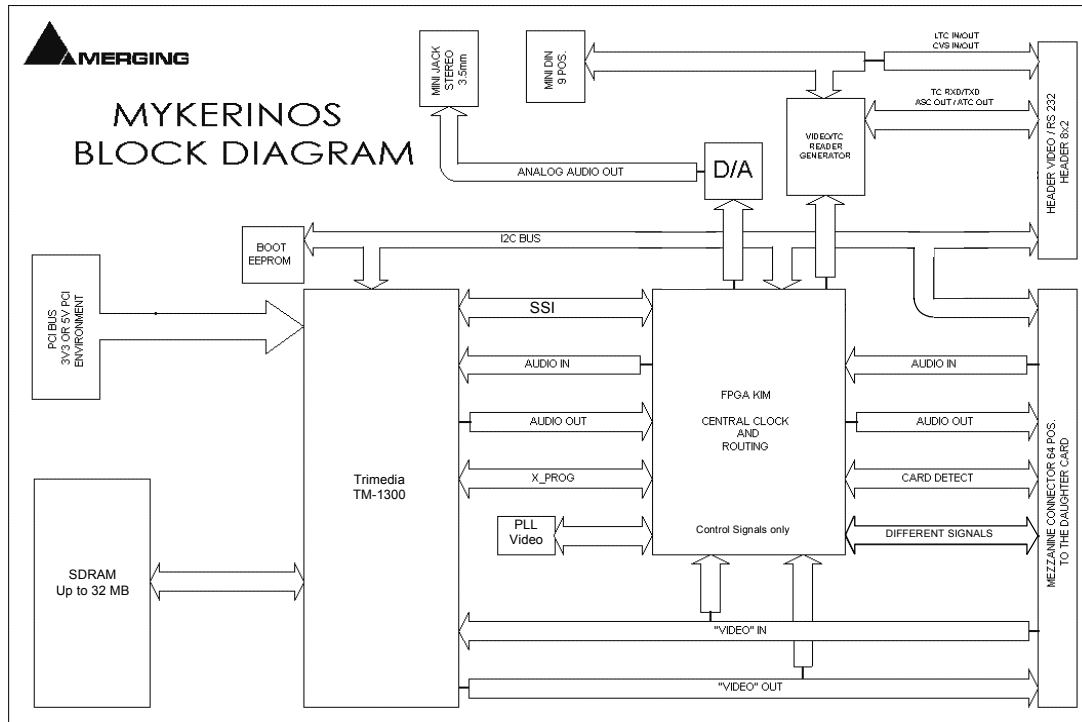

Figure 1 - Mykerinos Block Diagram

The Mykerinos board is based on the Philips Trimedia TM-1300 Chip and its associated SDRAM running at 168 MHz. The other peripherals are:

- 1 FPGA (Field Programmable Gate Array), used to manage the control signals
- 1 Timecode reader – generator (LTC and VITC)
- 1 Video PLL, used to lock to any incoming Video reference such as black-burst PAL, NTSC or Tri-level HDTV
- 1 stereo 24 bit 96kHz D/A for onboard audio monitoring.

Up to 64 audio channels are conveyed over the Trimedia high-speed “Video IN” and “Video OUT” buses through connector **J4** to/from the specific I/O daughter card.

6.2 Mykerinos On-Board Connectors and Jumpers

The connectors implemented on the Mykerinos board are as follows:

- **JP1** - header 1x2, Reserved.
- **JP2** - Video/TC connector 8x2, offering the same functionalities as J2 but for internal connection
- **JP3** - header 1x2, used to connect internally a Video Reference Sync (in lieu of CVS1IN signal)
- **J2** - 1 mini Din 8 pins, used to transfer Video and Timecode signals
- **J3** - 1 stereo headphone monitoring output 3.5mm mini-jack connector
- **J4** - 1 mezzanine connector 32x2, used to connect I/O daughter cards
- **JP4** - 75ohm termination for CVS1IN (input from J2, JP2 or JP3)
- **JP5** - 75ohm termination for CVS2IN (input from J2 or JP2)
- **JP6** - monitoring gain attenuation (-12dB when open) for the left channel
- **JP7** - monitoring gain attenuation (-12dB when open) for the right channel

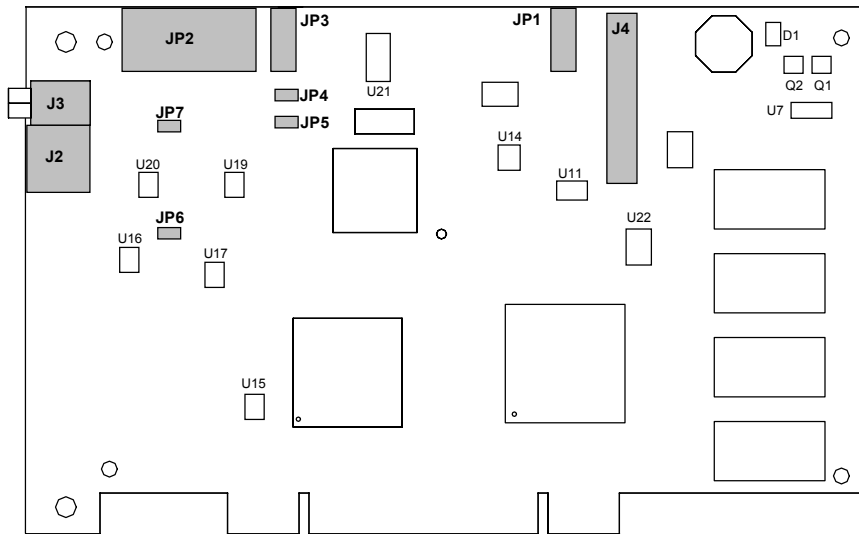

Figure 2 - Connectors & Jumpers layout

Refer to the “Sync Features” and “Monitoring Headphone Features” chapters for additional information.

6.3 Mykerinos bracket view

The following picture shows a view of the PCI bracket with the monitoring jack and the mini-Din connectors.

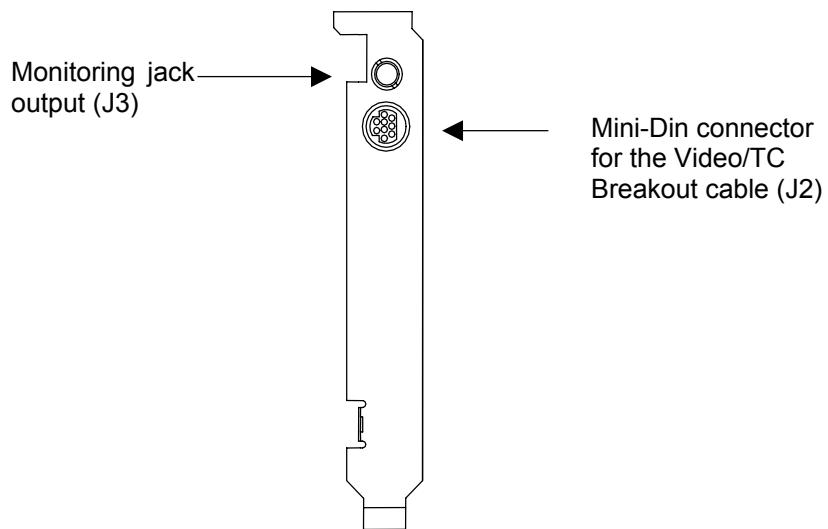

Figure 3 - Mykerinos Bracket with Jack & mini-Din connectors

7 Sync Features

Provision for all Video/TC related signals (VITC, LTC, and Video Sync) is both on a 9-pin Mini-Din connector (for external connection) and on a 16-pin header (for internal connection). The Video Out can also serve as VITC output and/or TC burn-in output.

The Mykerinos board supports all standard Video formats such as PAL/NTSC, and all Tri-level HDTV formats as a reference synchronization source. VITC can only be extracted from standard video formats. Here are the different possibilities offered by either the Video/TC bracket or breakout cable:

- NTSC/PAL/VITC Video Reference Input + HDTV reference sync source Input
- NTSC/PAL/VITC Video 2 Input or Wordclock I/O
- NTSC/PAL/VITC Video Output

- LTC (SMPTE/EBU) Timecode Input (balanced, nominal 2 Vp-p)
- LTC (SMPTE/EBU) Timecode Output (unbalanced, programmable level)

The breakout cable allows Mykerinos to lock to a video "house sync" or a Wordclock reference, read & generate VITC and read & generate LTC. This option also adds the capability to "burn" a Time code "insert" in the video output signal. This interface has provision for one BNC input CVS1In, one BNC Input/Output CVS2In/WCK, one BNC output CVS Out, one XLR Female for LTC input and one XLR Male for LTC output.

It is quite similar in functionality to the Video/TC bracket option. The main difference is in the loop through mode, which is not available with the breakout cable. Therefore the standard recommended setup is to have JP4 closed on the Mykerinos card to terminate the CVS1In signal with 75 Ohms on board and to leave open the similar jumper on the Video/TC bracket (to avoid double termination).

7.1 Signal Description

7.1.1 CVS1 IN

This input accepts a composite PAL/NTSC or Tri-level HDTV video signal that can be used by Mykerinos to lock its audio sampling rate to a video reference. The CVS1 input should be used for the main "house sync" or "black-burst" reference video signal. It is also possible to use this input as a VITC source (only standard PAL and NTSC rates).

Note: for proper operation this input should be terminated, with a 75ohm resistor, by closing the jumper **JP4** on Mykerinos when connected to the breakout cable.

7.1.2 CVS2IN / WCKIn&Out

This connector can be used, under software control, in 3 modes: Video 2 IN, Wordclock IN or Wordclock OUT.

When fed with a video signal it may be used as a secondary VITC source or an alternate video input to be used for the TC window inserter. It is however not possible to use it as the primary external video reference signal and requires at all times a "house-sync" signal connected to CVS1IN for proper operation.

Note: when used as a secondary Video Input with the breakout cable, it should be terminated with a 75ohm resistor by closing the jumper **JP5** on Mykerinos.

When software configured as a WCK Input it accepts an external Wordclock reference signal between 0.2 and 5 Vp-p.

When software configured as a WCK Output it provides a 5 V TTL-compatible signal with 100-Ohm output impedance.

Note: whenever used with a Wordclock signal (either Input or Output), do not terminate (JP5 open) on Mykerinos and on the Video/TC bracket.

7.1.3 CVS OUT

This signal outputs a composite video signal whose source can be software selected to be CVS1IN or CVS2IN. This signal may additionally carry a VITC and/or a time code "burn-in" video insert generated by Mykerinos.

Note: CVSOUT provides a monitoring quality video output only and is not intended to be used as a loopthrough "black burst" output.

7.1.4 LTC IN

LTC IN is a symmetrical input signal. It accepts an external SMPTE/EBU time code signal between 0.2 and 5 Vp-p.

7.1.5 LTC OUT

LTC OUT is an unbalanced output signal. The output voltage level can be software adjusted from 0V to 2.5V p-p.

7.2 Breakout Cable Pin-out description (J2)

The following picture describes the physical implementation of the signals on the mini Din male plug of the breakout cable.

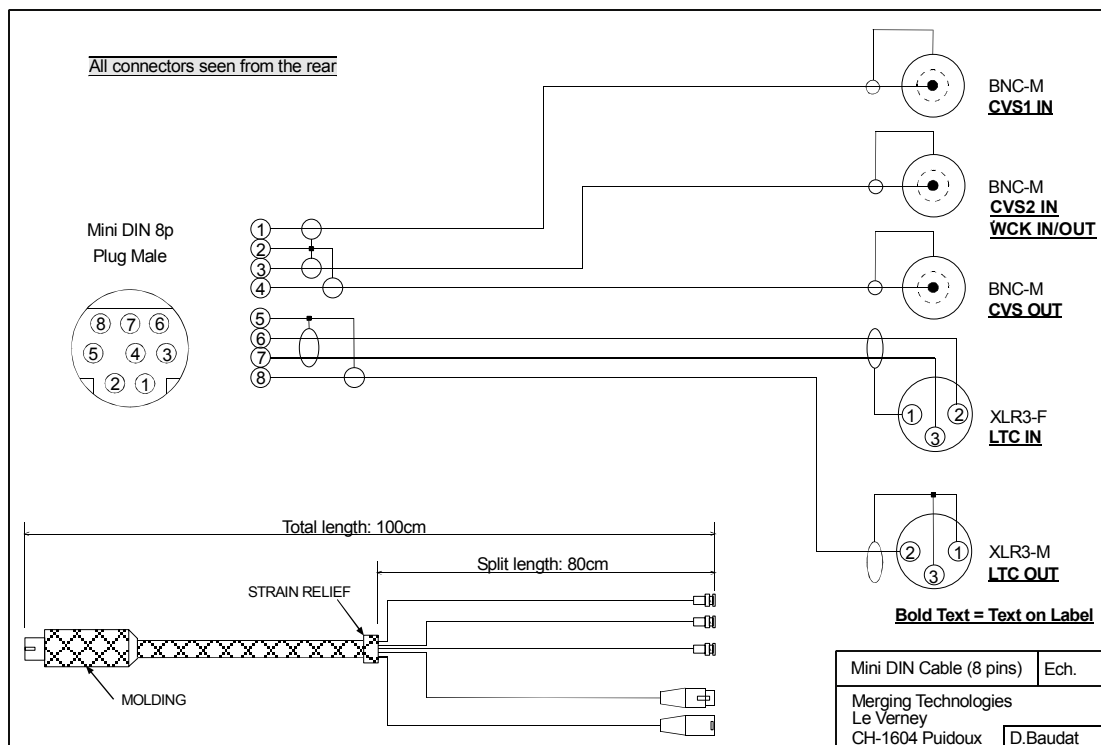

Figure 4 - Breakout Cable Pin-out

7.3 Video/TC Header Pin-out descriptions (JP2)

The pins on the Video/TC header are as described below:

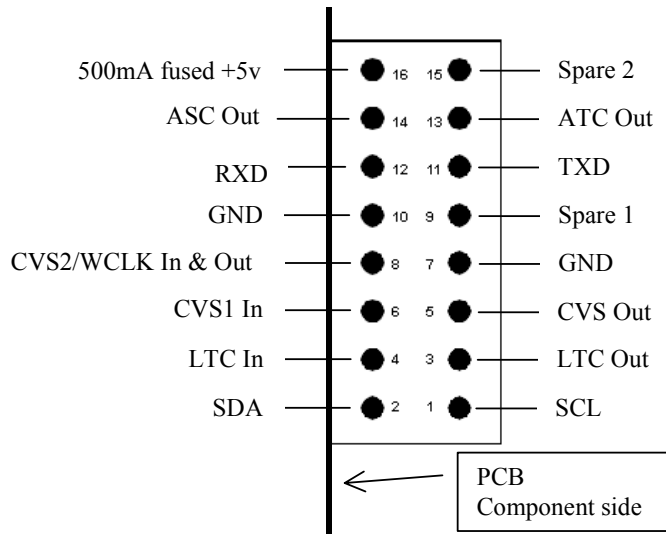

Figure 5 - Video/TC Header Pin-out

When the Video/TC Header is used, be sure to not terminate twice the CVS1IN and CVS2IN inputs. Use only either the terminations on the Mykerinos board (JP4 & JP5) or those provided on the Video/TC Header.

Here is a representation of the Video/TC bracket:

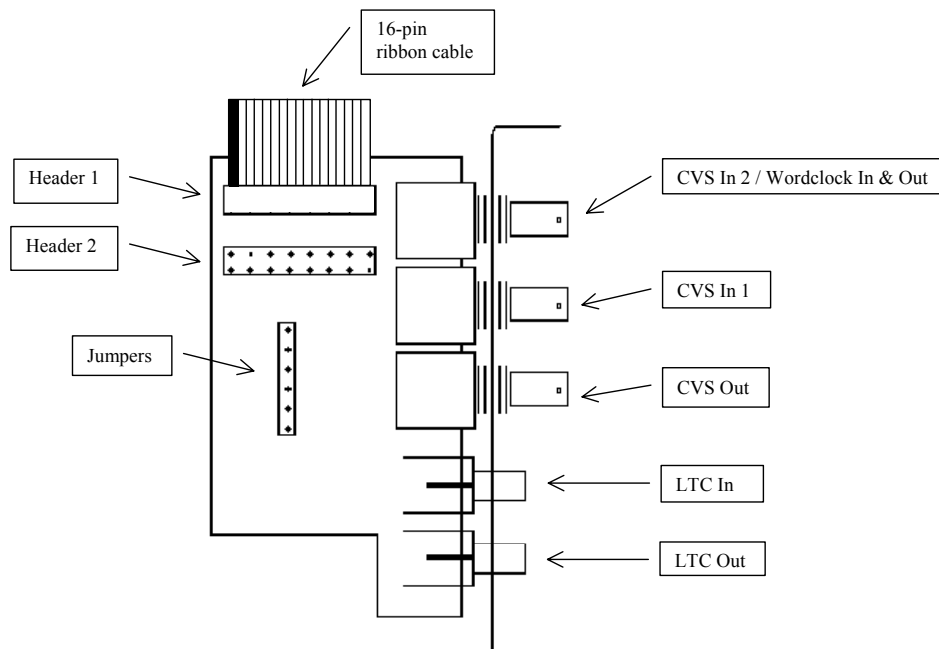

Figure 6 - Video/TC bracket

Terminology:

- CVS: Composite Video Signal, either NTSC, PAL or HDTV.
- LTC: Longitudinal Time Code, either SMPTE or EBU.
- VITC: Vertical Interval Time Code, either SMPTE on NTSC or EBU on PAL.
- SCL, SDA: Serial clock and Serial Data for I2C serial communication

8 Monitoring Headphone Features (J3)

The monitoring output is based on a stereo 96kHz / 24 bit D/A (unbalanced). The output level is software controlled.

Mykerinos revision D and above feature 2 new jumpers **JP6** and **JP7** on the left and right channels respectively. Opening these jumpers results in a 12 dB gain reduction on each monitoring channel.

8.1 Monitoring output characteristics

The first graph shows the frequency response & the THD+N @ 48kHz and the second graph shows the Noise floor FFT @ 48kHz .

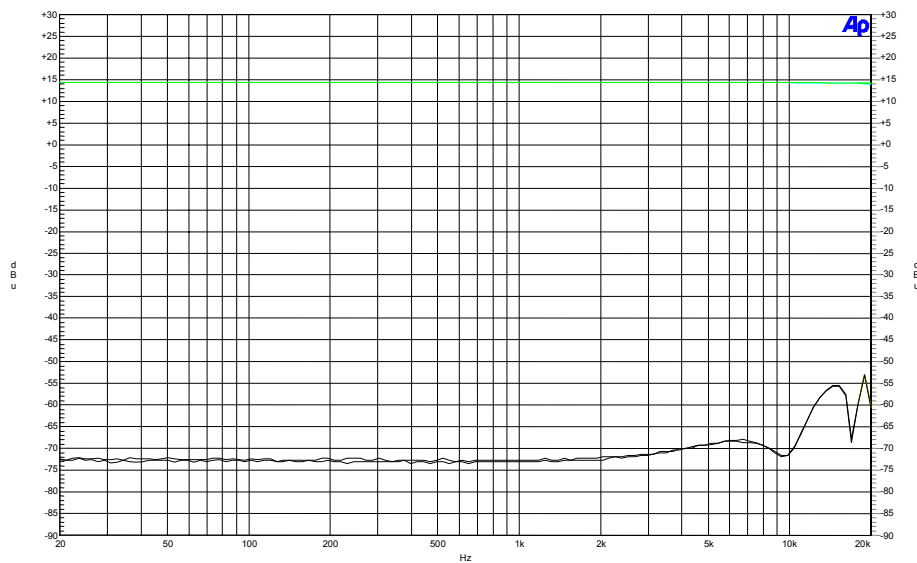

Figure 7 - Monitoring frequency response measurement

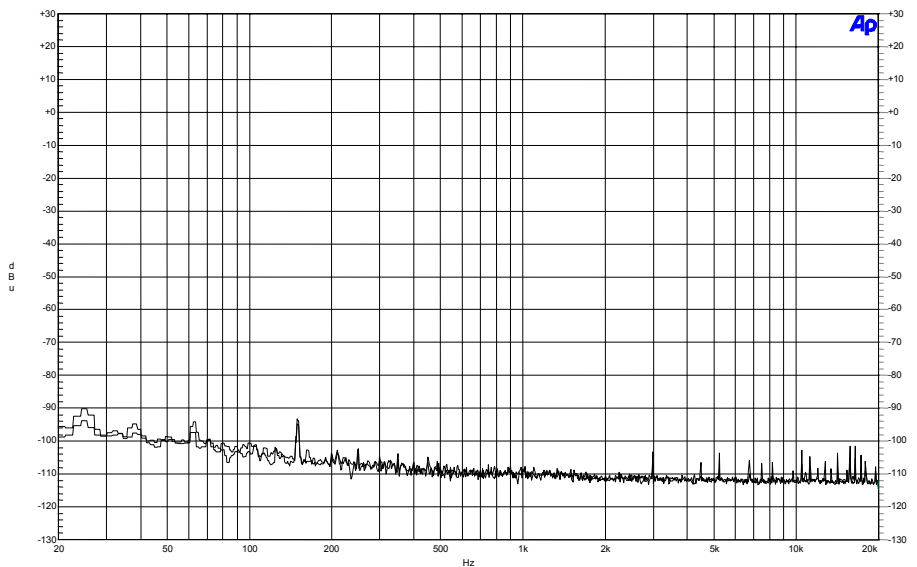

Figure 8 - Monitoring Noise spectrum measurement

9 Mykerinos Modular I/O Daughter cards

One core feature of Mykerinos' architecture is to break it into two parts: the portion that plugs into the PCI connector of the PC and the I/O daughter card that contains the physical connectors to the outside world. This allows for potentially many system applications without committing the design to any specific I/O configurations.

9.1 ADAT I/O Daughter Card

This I/O daughter card features two sets of Toslink Optical connectors each carrying up to eight channels of 24-bit Audio in the ADAT compatible format. This provides up to 16 mono channels of input and 16 channels of output up to 48kHz and up to 8 channels at 96kHz in S/MUX compatible format. One of the sets can be programmed in software to carry SPDIF (or AES-EBU) formatted signals instead of ADAT. In this mode, total I/O is limited to $2 + 8 = 10$ Digital Audio channels.

The following figure represents the configuration of the Mykerinos bracket when plugged with an ADAT daughter card.

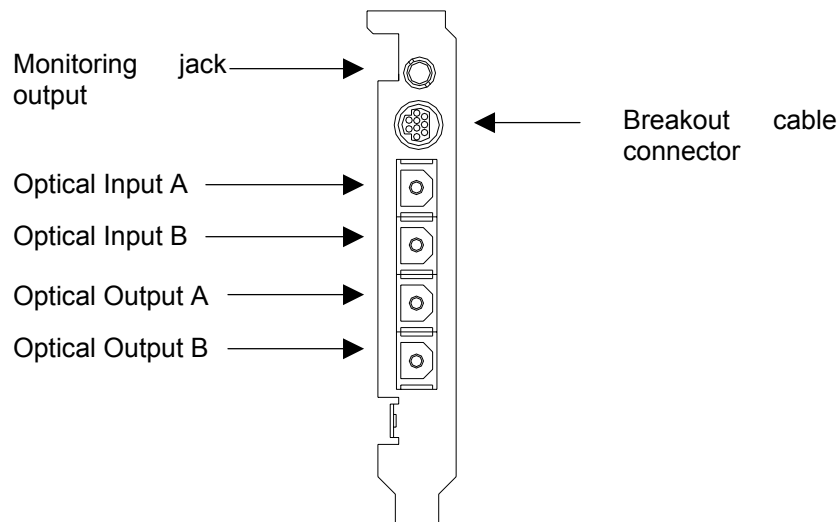

Figure 9 - Mykerinos & ADAT daughter card connectors

9.1.1 Optical I/O configuration

INPUT Modes

- | | | |
|------------------------------------|---|---------------------------------|
| A/ ADAT Channel 1 – 8 (Optical A) | - | ADAT Channel 9 – 16 (Optical B) |
| B/ SPDIF Channel 1 – 2 (Optical A) | - | ADAT Channel 9 – 16 (Optical B) |

OUTPUT Modes

- | | | |
|------------------------------------|---|---------------------------------|
| A/ ADAT Channel 1 – 8 (Optical A) | - | ADAT Channel 9 – 16 (Optical B) |
| B/ ADAT Channel 1 – 8 (Optical A) | - | ADAT Channel 1 – 8 (Optical B) |
| C/ SPDIF Channel 1 – 2 (Optical A) | - | ADAT Channel 1 – 8 (Optical B) |
| D/ SPDIF Channel 1 – 2 (Optical A) | - | ADAT Channel 9 – 16 (Optical B) |

The optical ADAT daughter card is supplied with two 2-meter optical fiber cables. Other length (up to 10 meter) can be ordered from your authorized Merging dealer.

For long distance optical connections, Merging provides the **Onouris** long distance system, which converts the ADAT plastic light-pipe into a signal suitable for glass fiber connection up to 1000 meters. Cables with various glass fiber lengths can also be supplied.

MADI I/O Daughter Card

The Mykerinos MADI Daughter board is the solution for high I/O channel count applications. It offers 56 channels of 24 bit bi-directional I/O and up to 64 channels in MADI-X (MADI Extended) format. It can be ordered either in a BNC based coaxial version or an optical duplex SC version. Both versions are fitted with a standard Wordclock BNC I/O connector, which can be software programmed as a Wordclock In or Wordclock Out signal.

9.2.1 Coaxial version connector view

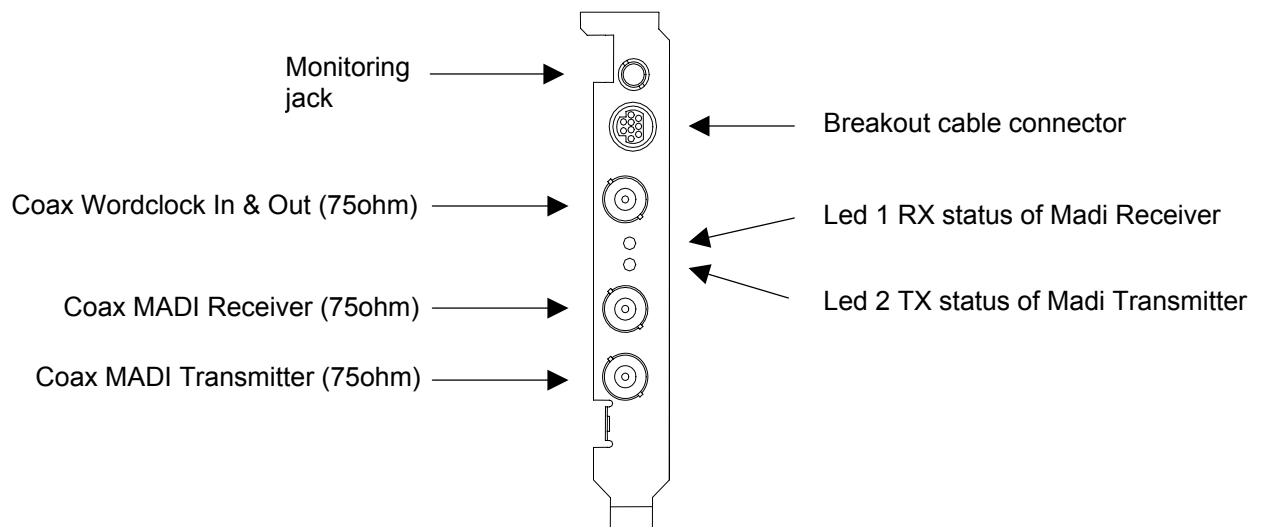

Figure 10 – Mykerinos & coaxial MADI daughter card connectors

9.2.2 Optical version connector view

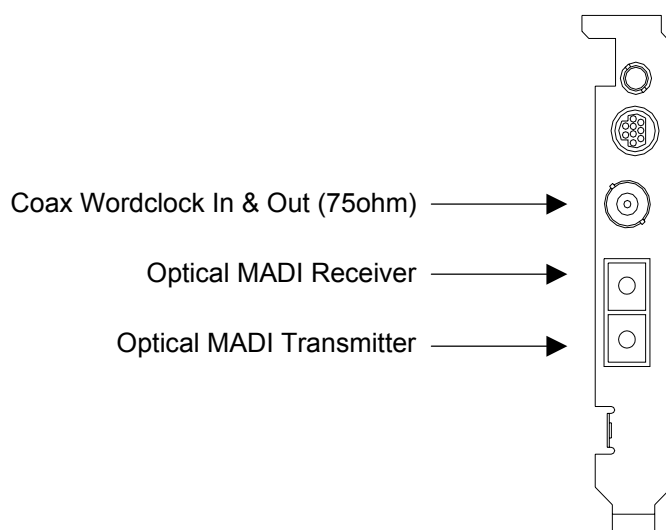

Figure 11 - Mykerinos & optical MADI daughter card connectors

9.3 AES-EBU, SDIF, TDIF I/O Daughter Cards

The Mykerinos AES-EBU Daughter board offers 24 channels of digital I/O over 12 AES-EBU input and output pairs. 8 channels feature real-time Sampling Rate Conversion from 32 to 96 kHz, which may be inserted either in the input or output signal path under software control. Both “single wire” (32 to 96 kHz) and “dual wire” (64 to 192 kHz) modes are supported under software control. Connection is over three DB-25 connectors (one primary on the daughter card itself, two additional connectors on separate ribbon cables). This option includes three DB-25 to XLR cables. Special versions with either SDIF or TDIF format instead of AES-EBU may also be offered.



Figure 12 - Location of the on-board connectors on the AES, SDIF & TDIF daughter cards

9.3.1 AES-EBU without SRC

- 24 channels of 24-bit digital input over 12 AES EBU pairs.
The organization of these channels are as follow:
- 24 channels of 24-bit digital output over 12 AES EBU pairs.

9.3.2 AES-EBU with SRC on 8 channels

- 24 channels of 24-bit digital input over 12 AES EBU pairs.
- 24 channels of 24-bit digital output over 12 AES EBU pairs.
- 8 (out of 24) channels feature SRC (Sampling Rate Converter) up to 96 kHz either on input or on output.

9.3.3 SDIF

- 12 channels of 20-bit digital input & output over 3 SDIF cables (connected to 3 DB25).

9.3.4 TDIF

- 24 channels of 24-bit digital input & output over 3 TDIF cables (connected to 3 DB25).

The table below is a summary of the different possibilities allowed with these 4 daughter cards.

	FRONT	REAR 0	REAR 1
AES without SRC	CH 1 – 8	CH 9 – 16	CH 17 – 24
AES with SRC	CH 1 – 8	CH 9 – 16	CH 17 – 24
SDIF	CH 1 – 4 (DSD only)	CH 5 – 8 (DSD only)	-
TDIF	CH 1 – 8	CH 9 – 16	CH 17 – 24

The AES with SRC provides 6 (Sony mode) or 4 (P3D mode) I/O of DSD channels through connectors Rear 0 and Rear 1. The AES without SRC provides 8 (Sony mode) or 6 (P3D mode) I/O of DSD channels through connectors Front, Rear 0 and Rear 1. The SDIF daughter card supports DSD only in both SDIF-2 and SDIF-3 format. Note that this daughter card does not use the Rear 1 connector.

The following figure represents the configuration of the Mykerinos bracket when combined with one of the AES, SDIF or TDIF daughter cards.

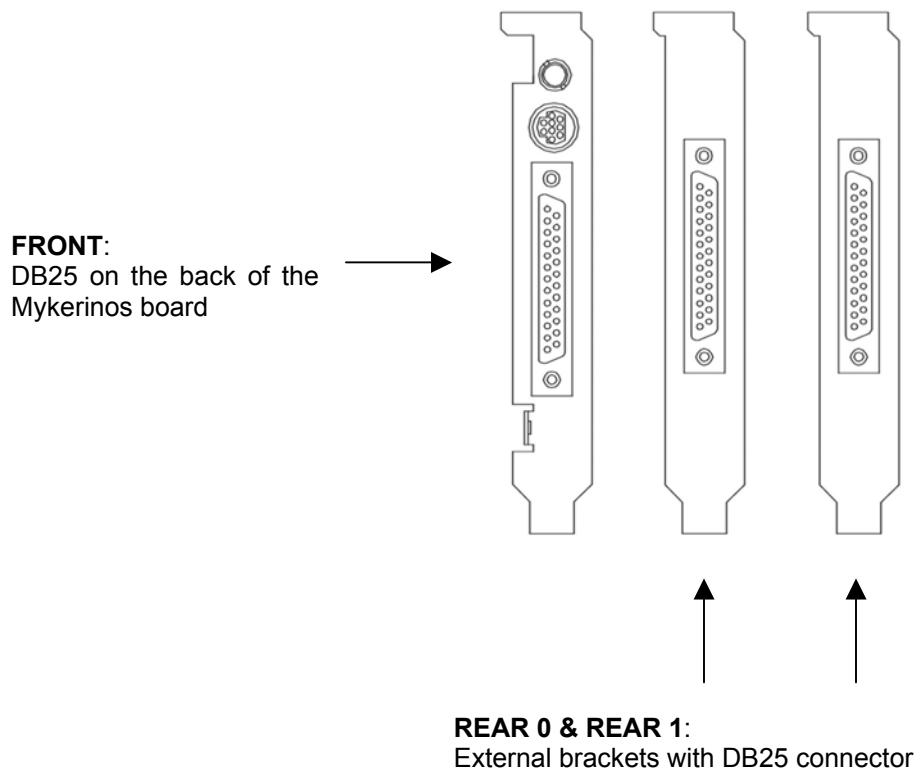

Figure 13 - Mykerinos & AES-EBU/SDIF/TDIF daughter card DB-25 connectors

9.4 DUAL Daughter Card

The Dual DC is the most cost-effective I/O daughter card for Pyramix. It is an ideal I/O solution for mixed analog/digital requirements, as encountered in Broadcast production, and Video/Film post-production environments. It allows the direct connecting of up to two electrodynamics or condenser microphones, typically for quick and easy voice-over recording.

9.4.1 Card Features

- Up to 12 inputs and 12 outputs on a single board:
 - 2 CH Analog Mic/Line inputs
 - 2 CH Analog Line inputs
 - 4 CH Analog Line outputs
 - 8 CH AES/EBU inputs
 - 8 CH AES/EBU outputs
- All audio connections are made using high-quality balanced XLR type connectors,
 - Provided by two DB-25 breakout cables.
- High quality 24 bit A/D and D/A using the latest generation in converter technology.
- 2 built-in microphone preamplifiers, with a selection MIC / LINE available on analog inputs 1 and 2.
- Built-in 48V microphone phantom power.
- Analog input and output level adjustment offering 24 dB range to accommodate all standard studio levels.
- Support for sampling rates 32 kHz, 44.1 kHz or 48 kHz.

The connection of the Dual daughter card is over two DB-25 connectors, one primary on the daughter card itself and one additional connector on a separate ribbon cable. See below:

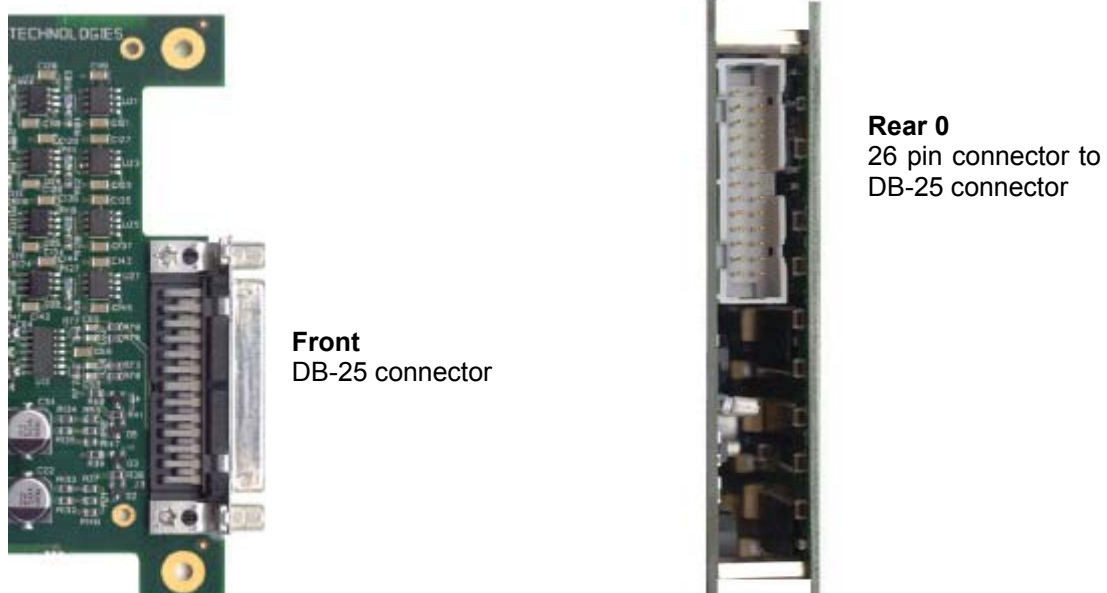
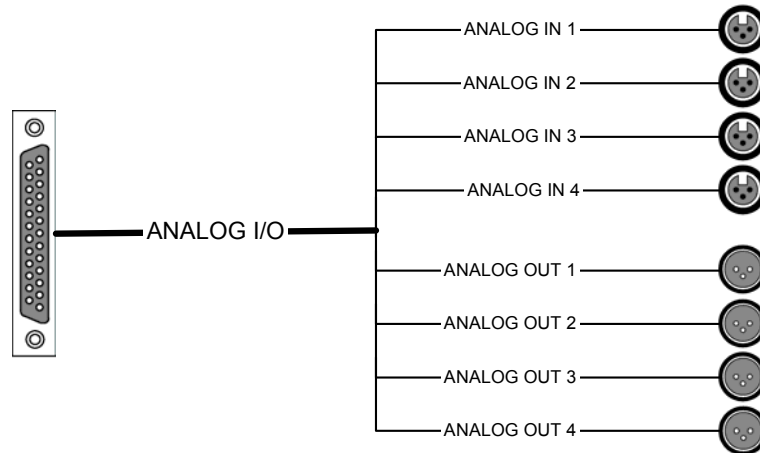

Figure 14 - Location of the on-board connectors on the DUAL daughter card

9.4.2 Front connector

This DB25 connector is for the DUAL **ANALOG** I/O breakout cable, as shown in the following drawing.



ANALOG IN 1 - 4

Any professional level balanced audio output can be connected to the analog line inputs of the DUAL Daughter card. Input levels are selectable from consumer level (-10 dBV) up to professional level (+4 dBu).

ANALOG OUT 1 - 4

Any professional level balanced audio input can be connected to the analog line outputs of the DUAL Daughter card. Output levels are selectable from consumer level (-10 dBV) up to professional level (+4 dBu).

9.4.3 Rear 0 connector

This DB25 connector is for the DUAL **AES/EBU** I/O breakout cable, as shown in the following drawing.

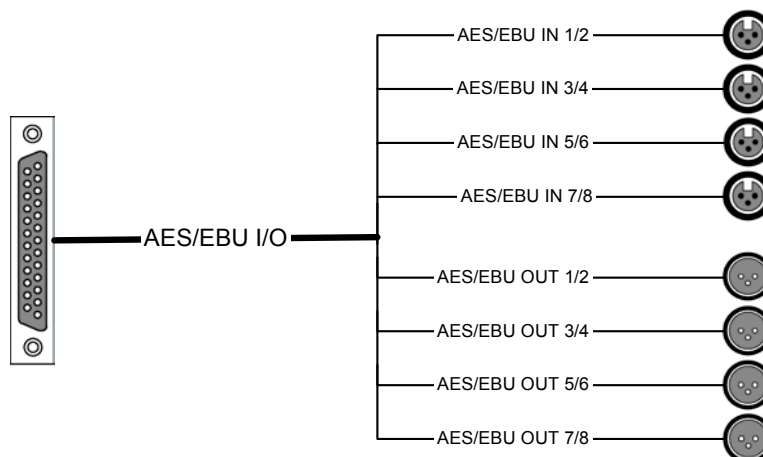

AES/EBU IN 1/2 - 7/8

Any professional level balanced digital AES/EBU audio output sources at 32, 44.1 or 48 KHz can be connected to the AES/EBU inputs of the DUAL Daughter card.

AES/EBU OUT 1/2 - 7/8

Any professional level balanced digital AES/EBU audio inputs at 32, 44.1 or 48 KHz can be connected to the AES/EBU outputs of the DUAL Daughter card.

9.5 Breakout cable connectors for AES, SDIF, TDIF and DUAL daughter cards

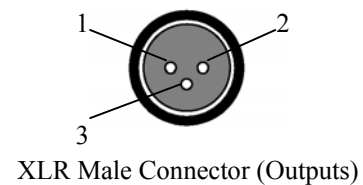
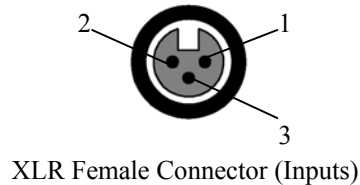
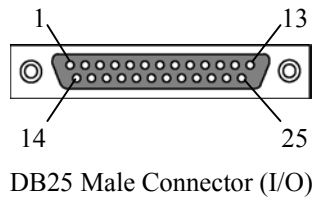

9.5.1 Analog I/O breakout cable – Only for the DUAL daughter card

XLR Label	XLR color	Signal	XLR-F	DB25-M	XLR Label	Cable Color	Signal	XLR-M	DB25-M
ANALOG IN 1	BROWN	AGND	1	9	ANALOG OUT 1	GREEN	AGND	1	5
		AIN1+	2	13			AOUT1+	2	1
		AIN1-	3	25			AOUT1-	3	14
ANALOG IN 2	RED	AGND	1	21	ANALOG OUT 2	BLUE	AGND	1	18
		AIN2+	2	12			AOUT2+	2	2
		AIN2-	3	24			AOUT2-	3	15
ANALOG IN 3	ORANGE	AGND	1	8	ANALOG OUT 3	PURPLE	AGND	1	6
		AIN3+	2	11			AOUT3+	2	3
		AIN3-	3	23			AOUT3-	3	16
ANALOG IN 4	YELLOW	AGND	1	20	ANALOG OUT 4	GRAY	AGND	1	19
		AIN4+	2	10			AOUT4+	2	4
		AIN4-	3	22			AOUT4-	3	17

Note: The DB25 pin 7 is connected to AGND.

9.5.2 AES/EBU I/O breakout cable

XLR Label	XLR Color	Signal	XLR-F	DB25-M	XLR Label	XLR Color	Signal	XLR-M	DB25-M
AES/EBU IN 1/2	BROWN	DGND	1	9	AES/EBU OUT 1/2	GREEN	DGND	1	5
		DIN1/2+	2	13			DOUT1/2+	2	1
		DIN1/2-	3	25			DOUT1/2-	3	14
AES/EBU IN 3/4	RED	DGND	1	21	AES/EBU OUT 3/4	BLUE	DGND	1	18
		DIN3/4+	2	12			DOUT3/4+	2	2
		DIN3/4-	3	24			DOUT3/4-	3	15
AES/EBU IN 5/6	ORANGE	DGND	1	8	AES/EBU OUT 5/6	PURPLE	DGND	1	6
		DIN5/6+	2	11			DOUT5/6+	2	3
		DIN5/6-	3	23			DOUT5/6-	3	16
AES/EBU IN 7/8	YELLOW	DGND	1	20	AES/EBU OUT 7/8	GRAY	DGND	1	19
		DIN7/8+	2	10			DOUT7/8+	2	4
		DIN7/8-	3	22			DOUT7/8-	3	17

Note: The DB25 pin 7 is connected to DGND.

10 Typical Audio Connections between DUA II & Mykerinos

This section will display some typical audio connection scenarios for DUA II and Mykerinos.

10.1 Audio for Video with SONY Digital BetaCam Users

This example is based on Video NLE & DAW users who are using the Mykerinos in conjunction with a DUA II audio interface and a Digital BetaCam video deck.

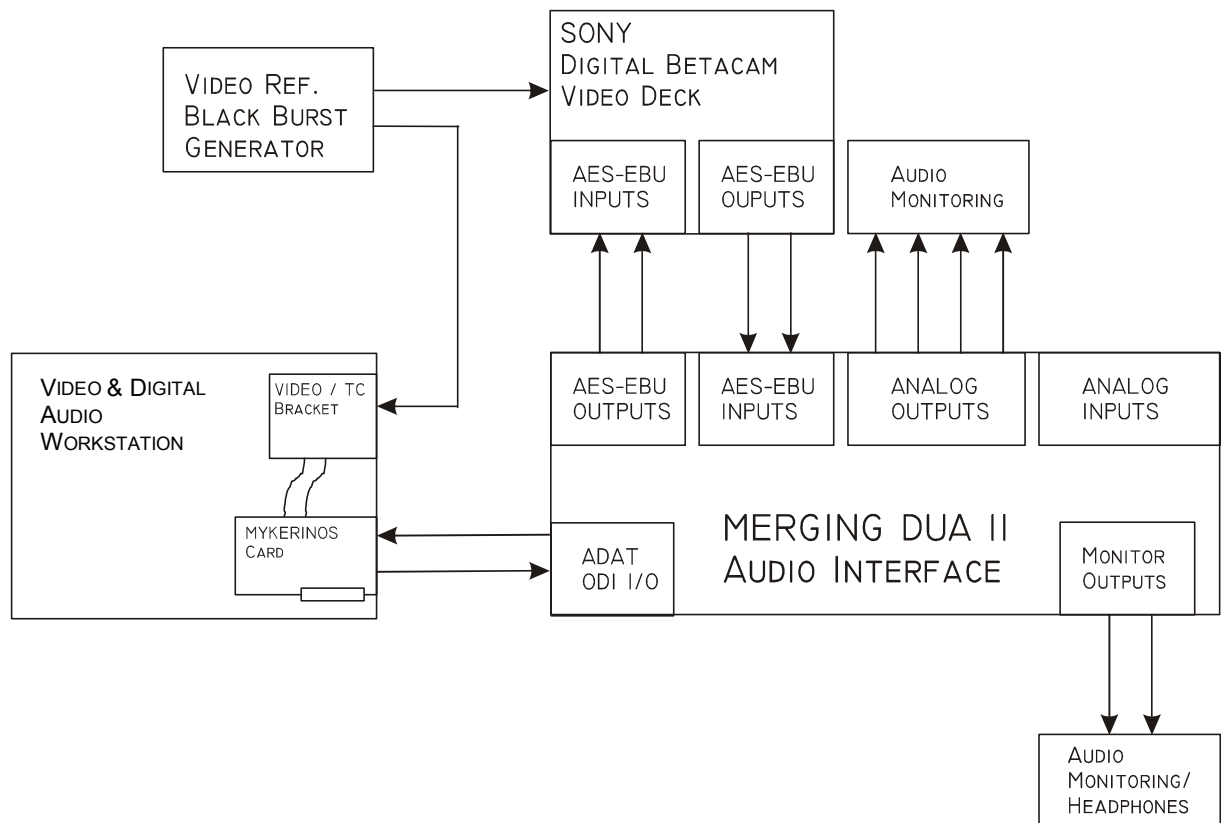

This example shows the following connections:

- The Digital BetaCam outputs are routed through the AES/EBU inputs of the DUA II to the Mykerinos input channels 1-4 (ADAT).
- The Mykerinos output channels 1-4 (ADAT) are routed through the AES/EBU outputs of the DUA II to the Digital BetaCam inputs.
- The Mykerinos output channels 1-4 (ADAT) are routed through the analog outputs of the DUA II to the monitoring system.
(Alternate monitoring is provided by the front panel monitoring selection of the DUA II or the stereo monitoring of the Mykerinos board).
- The Mykerinos card (via VIDEO/TC bracket or the breakout cable - CVS11N Input) and the Video Deck are connected to the Video Ref. generator.
Note that each device should be connected to the video generator with its own cable.
Using the Loop-Through to connect the different devices is not recommended.
- The DUA II is set to **ODI** sync mode and **AutoDetect SR** mode.
- The DIP switches 1-8 must be set to: **X – X – X – X – OFF – OFF – OFF – OFF**.

10.2 Audio for Video with SONY Analog BetaCam Users

This example is based on Video NLE & DAW users who are using the Mykerinos board in conjunction with DUA II audio interface and an Analog BetaCam video deck.

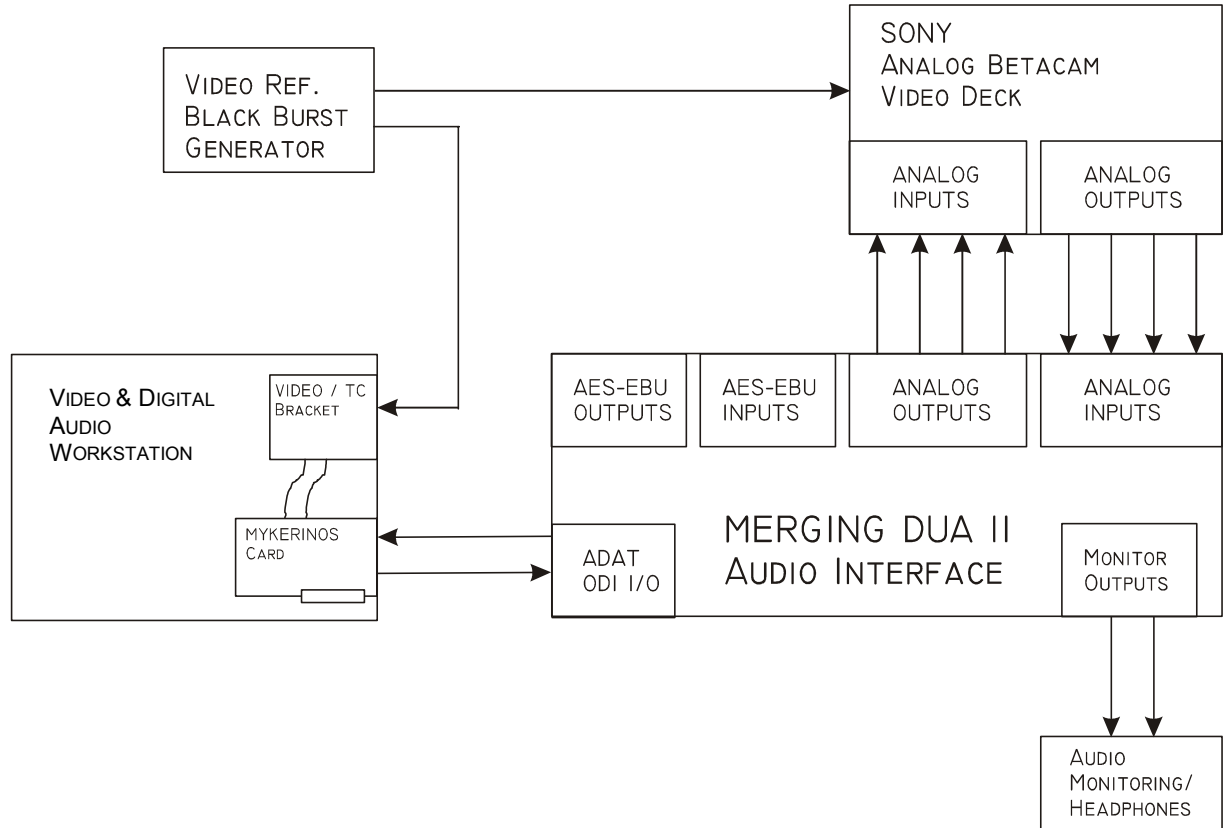

This example shows the following connections:

- The Analog BetaCam outputs are routed through the analog inputs of the DUA II to the Mykerinos input channels 1-4 (ADAT).
- The Mykerinos output channels 1-4 (ADAT) are routed through the analog outputs of the DUA II to the Analog BetaCam inputs.
- The monitoring is provided by the front panel monitoring selection of the DUA II or through the stereo monitoring of the Mykerinos board.
- The Mykerinos card (via VIDEO/TC bracket or the breakout cable - CVS11N Input) and the Video Deck are connected to the Video Ref. generator.
Note that each device should be connected to the video generator with its own cable.
Using the Loop-Through to connect the different devices is not recommended.
- The DUA II is set to **ODI** sync mode and **AutoDetect SR** mode.
- The DIP switches 1-8 must be set to: **X – X – X – X – OFF – OFF – OFF – OFF**.

10.3 Merging Technologies Pyramix 3.x DAW with Surround Monitoring

This example is based on a typical Pyramix analog/digital audio studio with both types of devices and a surround monitoring system.

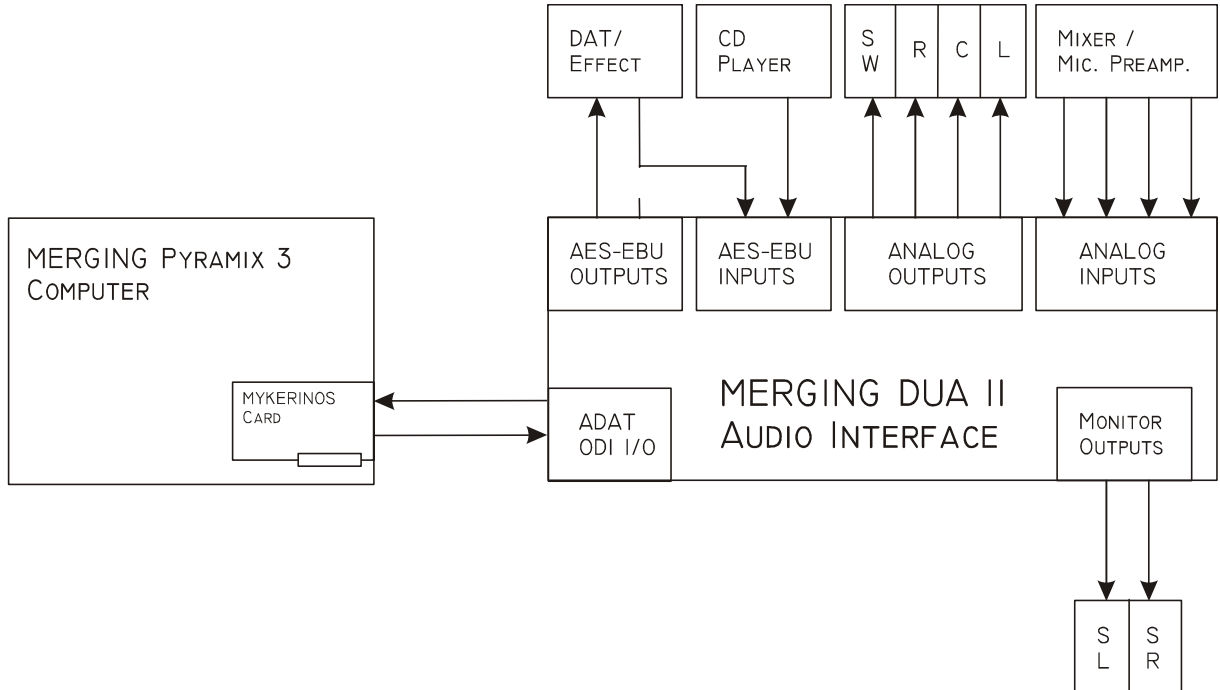

This example shows the following connections:

- The Mic Preamp/Mixer outputs are routed through the analog inputs of the DUA II to Pyramix input channels 1-4 (ADAT)
- The DAT/Effect/CD-Player outputs are routed through the AES/EBU inputs of the DUA II to the Pyramix input channels 5-8 (ADAT)
- The Pyramix output channels 1-4 (ADAT) are routed through the analog outputs of the DUA II to the monitoring system.
(In this example: CH1 = Left / CH2 = Center / CH3 = Right / CH4 = Subwoofer)
- The Pyramix output channels 5-6 (ADAT) are routed through the monitor outputs of the DUA II to the monitoring system (In this example: Left = Left Surround / Right = Right Surround)
- Pyramix output channels 7-8 (ADAT) are routed through AES/EBU outputs of DUA II to the DAT/Effect.
(In this example: It may be a simple Stereo Mix to be recorded on DAT, or a send for external effect)
- The DAT/Effect must use its AES/EBU input as its sync source.
- The DUA II is set to **ODI** sync mode, **AutoDetect SR** mode and **OUT5/6** monitoring.
- The DIP switches 1-8 must be set to: **X – X – X – X – OFF – ON – OFF – OFF.**

11 Typical Audio Connections between Sphynx & Mykerinos

This section will show some typical audio connection scenarios for the Sphynx Audio Interface and the Mykerinos board.

11.1 Audio for Video with SONY® Digital BetaCam Users

This example is based on Video NLE & DAW users who are using the Mykerinos board in conjunction with the Sphynx Audio Interface and a Digital BetaCam video deck.

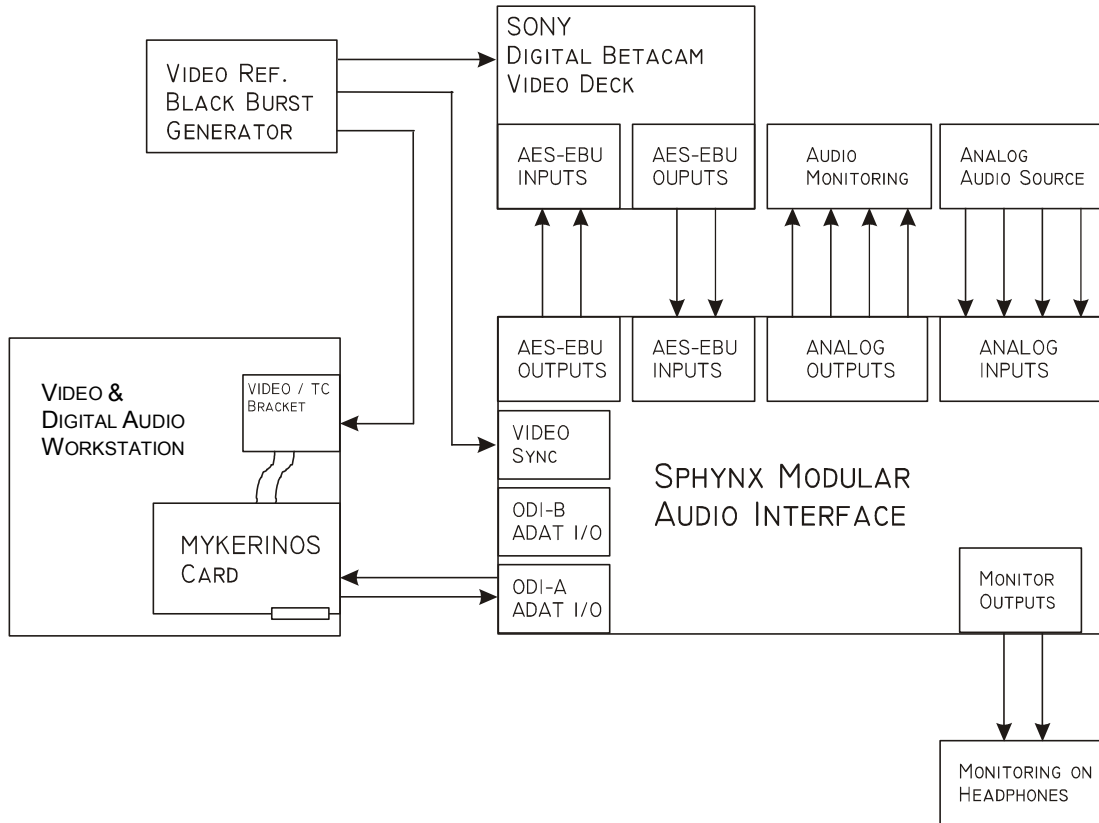

This example shows the following connections:

- Monitoring can be done through the Digital BetaCam analog outputs, the Sphynx headphones output, the Sphynx analog outputs (if analog output modules are installed) or the stereo monitoring connector of the Mykerinos board.
- The Sphynx contains at least 2 AES-EBU input modules (4 mono inputs) and 2 AES-EBU output modules (4 mono outputs). Analog output modules are optional in this configuration.
- All units (The Mykerinos board via the TC card or breakout cable CVS11N input, Video Deck and Sphynx) are connected to the video reference generator.
Note that any composite video source can also be used as a video reference for Sphynx.
- Note that the video loop output can be used to supply the video reference to other devices. Otherwise, a 75-Ohms terminator must be connected to the Loop output.
- The Sphynx is set to VIDEO or AES-EBU Sync Mode.

11.2 Audio for Video with SONY® Analog BetaCam Users

This example is based on Video NLE & DAW users who are using the Mykerinos board in conjunction with the Sphynx Audio Interface and an Analog BetaCam video deck.

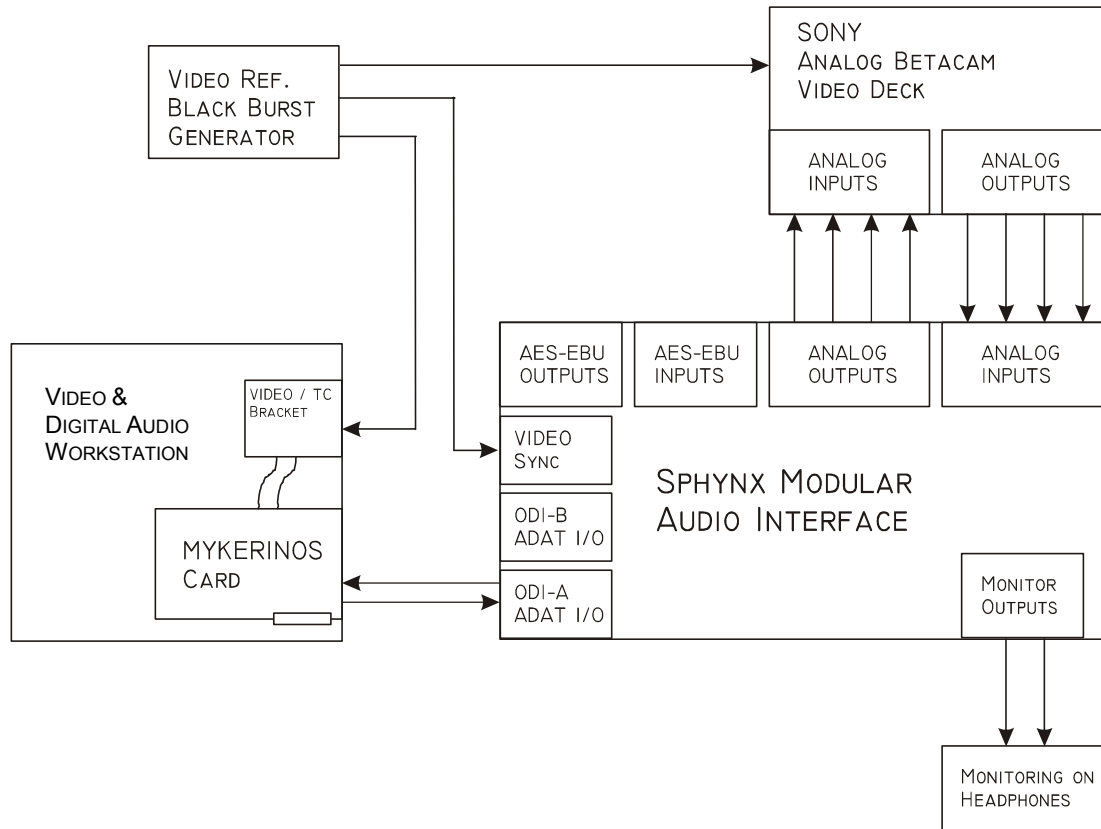

This example shows the following connections:

- The monitoring is done by the front panel Monitoring selection & output or through the stereo monitoring connector of the Mykerinos board.
- The Sphynx contains 2 analog input modules (4 inputs) and 2 analog output modules (4 outputs). AES/EBU output modules are optional in this configuration.
- All units (The Mykerinos board via the TC card or breakout cable CVS11N input, Video Deck and Sphynx) are connected to the Video Sync generator.
Note that any composite video source can also be used as a Video Sync reference for the Sphynx.
- Note that the Video Loop output of the Sphynx can be used to supply the video reference to other devices. Otherwise, a 75-Ohms terminator must be connected to the Loop output.
- The Sphynx is set to VIDEO Sync Mode

11.3 Merging Technologies Pyramix 3.x DAW Setup

This example is based on a typical Pyramix analog/digital audio studio with both types of devices. This configuration allows up to 8 inputs and 8 outputs in 'x2' SR mode.

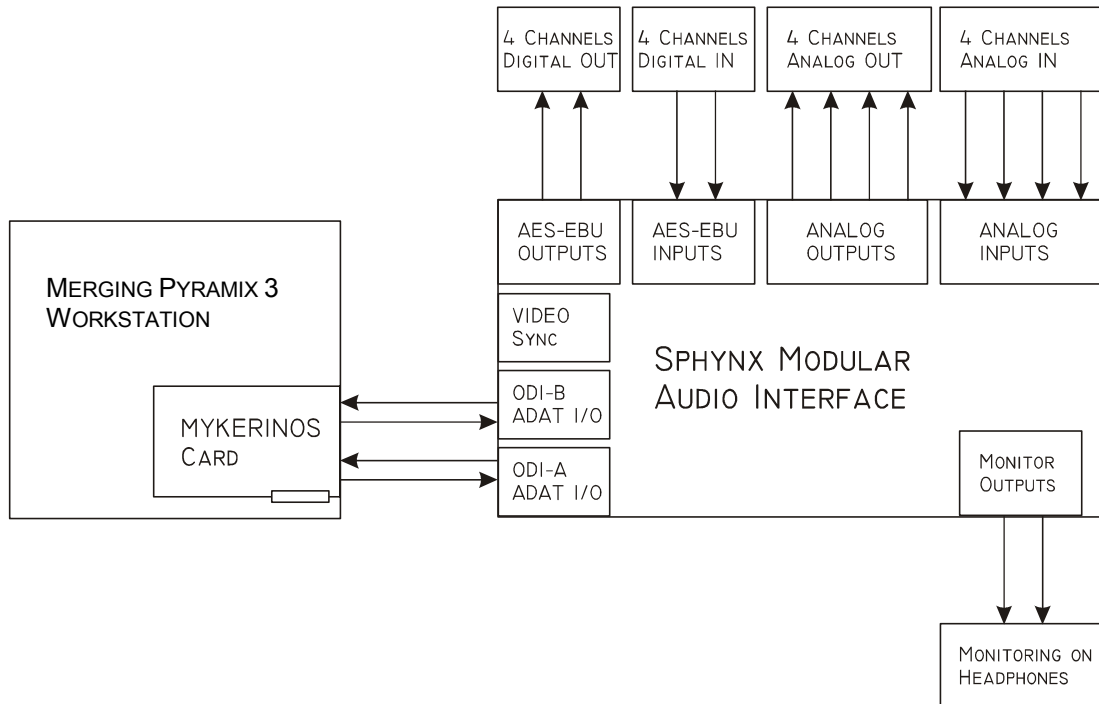

This example shows the following connections:

- All monitoring is done by the front panel monitoring selection & output and/or the analog output modules or the stereo monitoring of Mykerinos.
- The Sphynx is fitted with analog input modules and AES-EBU output modules.
- The Sphynx is set to INT Sync mode

12 Mykerinos Power Consumption

The power consumption of the Mykerinos board depends on which daughter card is present. The following tables indicate the maximum power consumption from the 5V, -12V and +12V power rails of the PC.

12.1 Mykerinos

Symbol	Standby	With EepromCfg			Units
	+5V	-12V	+12V	+5V	
Current	560			850	mA
Power dissipation	2.8			4.25	W

Note - Mykerinos alone cannot be tested under Pyramix. The EepromCfg test gives an idea of the power consumption for the Mykerinos motherboard only.

12.2 Mykerinos & ADAT daughter card

Symbol	Standby	Pyramix			Units
	+5V	-12V	+12V	+5V	
Current	640	80	80	1100	mA
Power dissipation	3.2	~1	~1	5.5	W

12.3 Mykerinos & MADI daughter card

Symbol	Standby	Pyramix			Units
	+5V	-12V	+12V	+5V	
Current	1100			1600	mA
Power dissipation	5.5			8	W

12.4 Mykerinos & AES-EBU without SRC

Symbol	Standby	Pyramix			Units
	+5V	-12V	+12V	+5V	
Current	N.A.			N.A.	mA
Power dissipation	N.A.			6.5	W

12.5 Mykerinos & AES-EBU with SRC

Symbol	Standby	Pyramix			Units
	+5V	-12V	+12V	+5V	
Current	N.A.			N.A.	mA
Power dissipation	N.A.			9	W

12.6 Mykerinos & SDIF or TDIF daughter cards

Symbol	Standby	Pyramix			Units
	+5V	-12V	+12V	+5V	
Current	N.A.			N.A.	mA
Power dissipation	N.A.			6.5	W

12.7 Mykerinos & Analog – AES/EBU (DUAL) daughter card

Symbol	Standby	Pyramix			Units
	+5V	-12V	+12V	+5V	
Current					mA
Power dissipation					W

13 Contacting Merging

For all general or sales inquiries:

In Europe, Africa and Asia contact our Swiss Office:

Merging Technologies SA
Le Verney
1070 Puidoux
Switzerland

Phone: +41 21 946 0444
Fax: +41 21 946 0445

In the Americas, contact our Illinois Office:

Merging Technologies
3000 Dundee Road
Suite 316
Northbrook, IL 60062
United States of America

Phone: +1 847 272 0500
Fax: +1 847 272 0597

Merging website: www.merging.com

All documentation inquiries, bug reports or suggestions for improvement can be directed to: info@merging.com